

Bearing selection

Products Series

AISI 440C

AISI 304

AISI 630

Pure Titanium

Ceramic

Heat Resistance

Grease Free

Low Torque

Solid Grease

Set Screw

Alignment Function

Flange Unit

Guide Wheel

6800
6900

SS5200
5200

5800

Customization

Examples of Use

SB Series Stainless Bearings with Aligning Ring (for outer ring rotation)



Corrosion resistance



High-load environment



Transportation



This bearing has an alignment function, implemented by incorporating an alignment ring inside the inner ring.

Features

1. Used for outer ring rotation
2. The alignment function reduces the abnormal load on bearings caused by deflection of rollers, etc.

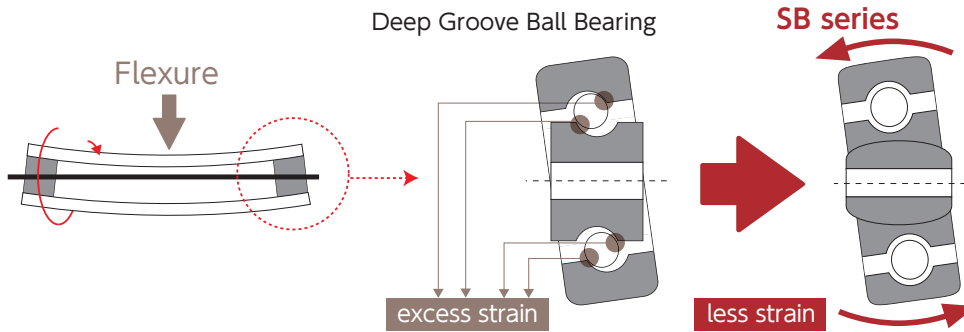

Product Specifications

Standard Specifications	
Inner and Outer Rings	AISI 440C
Aligning Ring	AISI 440C
Balls*1	AISI 440C
Retainer	AISI 304
Shield	AISI 304
Seal*2	Nitrile rubber
Lubricant*3	Heat-resistant grease

The following special specifications are also available.

- *1 Ceramic balls (Silicon Nitride Si₃N₄)
- *2 Fluorine rubber seal
- *3 Chemical- and heat-resistant fluorine grease, food-grade grease, and other special greases

Composition of bearing number

SS 00200 ZZ SB

1 2 3 4

- 1 SS : Material AISI 440C
- 2 Basic number
- 3 Blank : Open
ZZ : Double steel plate shields
2RS : Double contact rubber seals
- 4 SB : Aligning ring (for outer ring rotation)

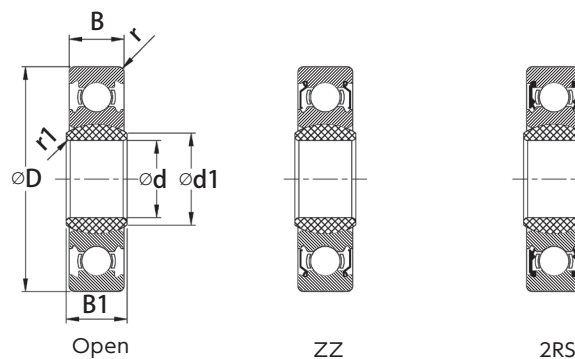

Table of Dimensions

Bearing Numbers	d	D	B	B1	d1	r min.	r1 min.	Basic Load Ratings	
								C _r	C _{0r}
								N	N
SS 00200 SB	10	32	9	10	12.8	0.3	0.3	5600	2840
SS 00301 SB	12	35	10	11	14.8	0.3	0.3	6000	3250
SS 00402 SB	15	42	12	13	17.3	0.6	0.3	9400	5050
SS 00503 SB	17	47	12	14	21.7	0.6	0.6	10100	5850
SS 00604 SB	20	55	13	15	26.5	1.0	1.0	13200	8300
SS 00705 SB	25	62	14	16	31.4	1.0	1.0	16000	10300
SS 00806 SB	30	68	15	17	36.4	1.0	1.0	16800	11600
SS 00907 SB	35	75	16	18	41.4	1.0	1.0	21000	15100

Bearing selection

Products Series

AISI 440C

AISI 304

AISI 630

Pure Titanium

Ceramic

Heat Resistance

Grease Free

Low Torque

Solid Grease

Set Screw

Alignment Function

Flange Unit

Guide Wheel

6800
6900

SS5200
5200

5800

Customization

Examples of Use